

8 7 6 5 4 3 2 1

F
E
D
C
B
A

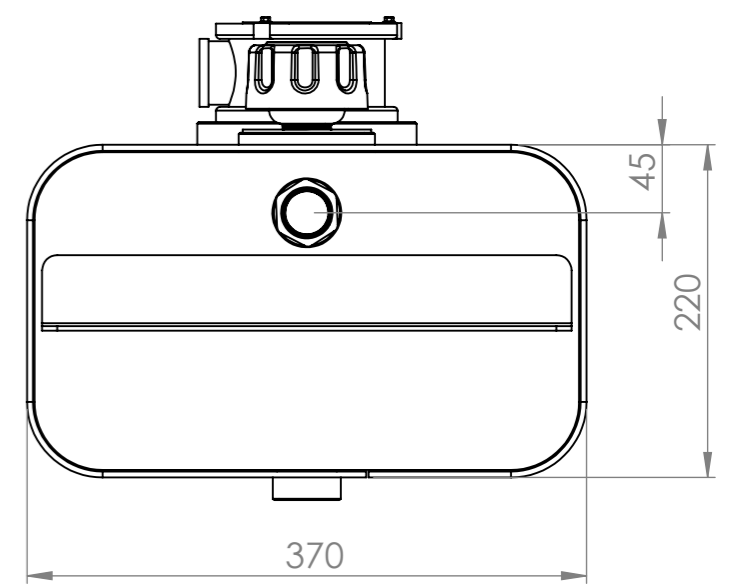

35 LITER TANK

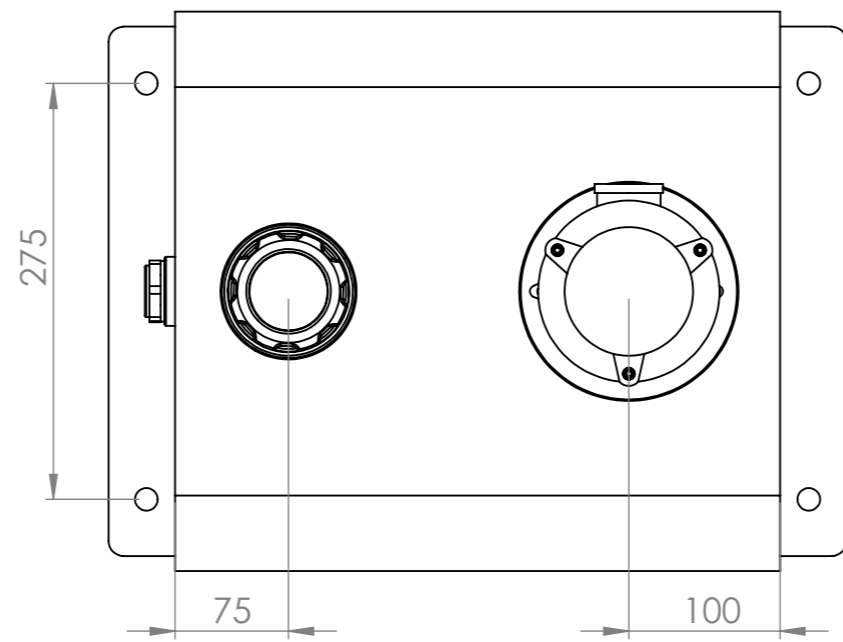
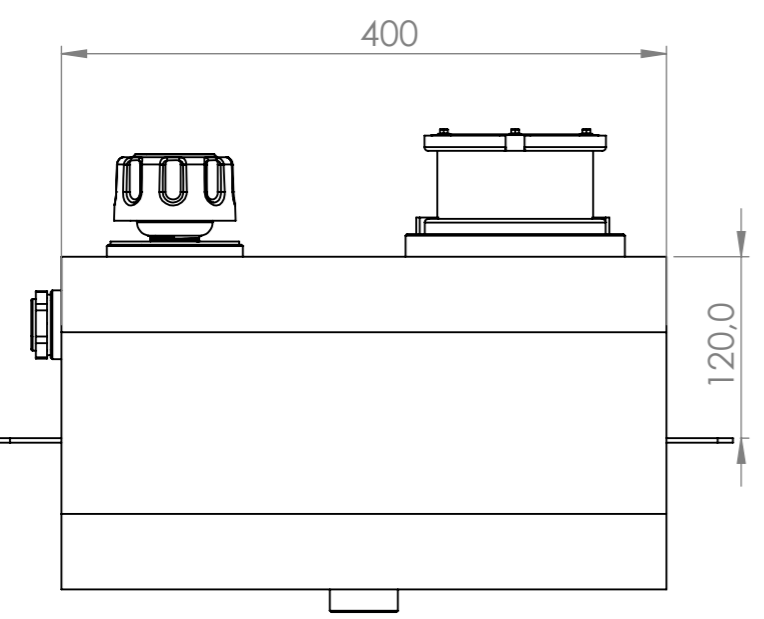
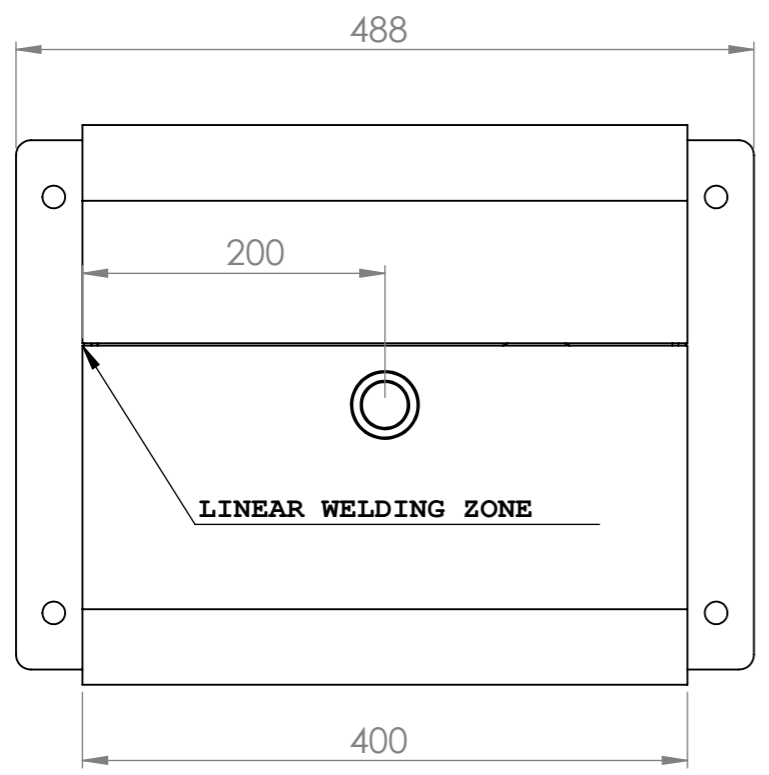

| | | | | | | | |
|-----------------------|----------------------------|----------------------------------------------|-----------------|--------------------------------------------|---------|---------|------|
| Malzeme (Material) | | | | | | | |
| PAINTED STEEL | | | | | | | |
| Genel Tolerans Sınıfı | | | | | | | |
| | Rev.No. | Rev.Tar. | Rev.Açıklaması | Rev.Yapan | Kontrol | Onay | |
| Özel karakteristik | Referans no | Ağ. (Kg) | Boya Kodu | Kaplama | | Dekor | |
| SS=0 Se=0 | 00 | | Yeni çizildi | H.KAYA | H.KILIÇ | R.KAYA | |
| Ölçek | Sistem | Rev.No. | Rev.Tar. | Rev.Açıklaması | Çizen | Kontrol | Onay |
| | SOLID WORKS VER.2019 | Parça Adı / Part Name | | | | | |
| Tolerans | | 370x220x400- STEEL Oil Tank-0359-35LT | | | | | |
| | Proje Metodu ISO 5456-2 | Format | Sayfa Sayısı | Resim No / Basic Number | | | |
| | HAYNEKS A.Ş. | A3 | 1/1 | OT-ST-370220400-RM-RF-VT-NG-MKW-035 | | | |

8 7 6 5 4 3 2 1

F
E
D
C
B
A



35 LITER TANK

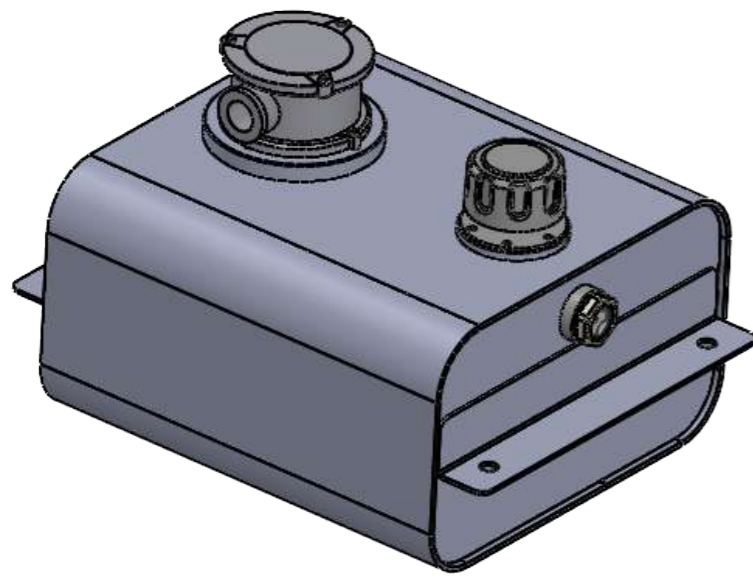

| Öğe No | Parça Adı | Tanım | Malzeme | Adet | Kalınlık |
|--------|-------------------|----------------------------|---------|------|----------|
| 1 | Tank Body | Gövde Sacı | Steel | 1 | 2 |
| 2 | Side Plate | Yan Duvar Sacı | Steel | 2 | 4 |
| 3 | Indicator Muff | G 1" Gösterge Manşonu | Steel | 1 | - |
| 4 | Spy Eye | G 1" Dana Göz | 6061-T6 | 1 | - |
| 5 | Bracket | 50x3mm Köşebent | Steel | 2 | 3 |
| 6 | G 1" Female Muff | G 1" Dişi Manşon | Steel | 1 | - |
| 7 | Steel Filling Cap | Metal Dolum Kapağı | Steel | 1 | - |
| 8 | Ø90 Flange | Kapak Bağlantı Flanşı 8mm | Steel | 1 | 8 |
| 9 | Ø145 Flange | Filtre Sistemi Bağ. Flanşı | Steel | 1 | 15 |
| 10 | Filter System | Geri Dönüş Filtresi-Alm | 6061-T6 | 1 | - |

| Malzeme (Material) | | | | | | | | | | | |
|-----------------------|--|-------------------------|--|-----------------------|--|----------------|--|-------------------------------------|--|-------------------------|--|
| PAINTED STEEL | | | | | | | | | | | |
| Genel Tolerans Sınıfı | | | | | | | | | | | |
| Özel karakteristik | | Rev.No. | | Rev.Tar. | | Rev.Açıklaması | | Rev.Yapan | | Kontrol | |
| SS=0 Se=0 | | 00 | | Yeni çizildi | | H.KAYA | | H.KILIÇ | | R.KAYA | |
| Ölçek | | Sistem | | Rev.No. | | Rev.Tar. | | Rev.Açıklaması | | Çizen | |
| Tolerans | | SOLID WORKS VER.2019 | | Parça Adı / Part Name | | Format | | Sayfa Sayısı | | Resim No / Basic Number | |
| | | HAYNEKS A.Ş. | | A3 | | 1/2 | | OT-ST-370220400-RM-RF-VT-NG-MKW-035 | | | |
| | | Proje Metodu ISO 5456-2 | | | | | | | | | |