

**200 LITER  
working volume**

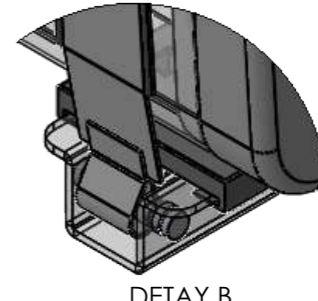

Malzeme (Material)		Sipariş Adet	Sipariş No					
<b>Steel-DKP</b>								
Genel Tolerans Sınıfı								
Özel karakteristik		Rev.No.	Rev.Tar.	Rev.Açıklaması	Rev.Yapan	Kontrol	Onay	
<b>SS=0 Se=0</b>		Referans no	Ağ. (Kg)	Boya Kodu	Kaplama		Dekor	
<b>Ölçek</b>		00		Yeni çizildi	H.KAYA	H.KILIÇ	R.KAYA	
<b>Sistem</b>		Rev.No.	Rev.Tar.	Rev.Açıklaması	Çizen	Kontrol	Onay	
Tolerans		SOLID WORKS VER.2019		Parça Adı / Part Name				
		320x640x1100 mm		<b>Steel Oil Tank (Çelik Yağ Deposu)</b>				
Proje Metodu		Format	Sayfa Sayısı	Resim No / Basic Number				
ISO 5456-2		A3	1/1					
Copy Right Hayneks All rights Reserved					<b>HAYNEKS</b>			

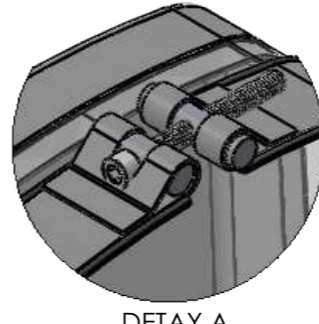
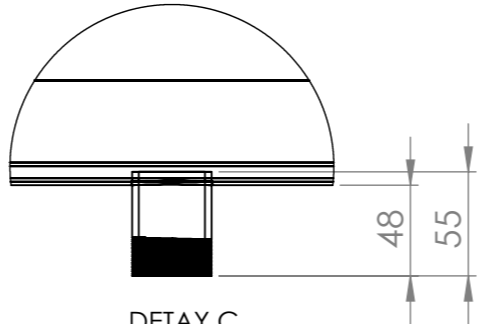
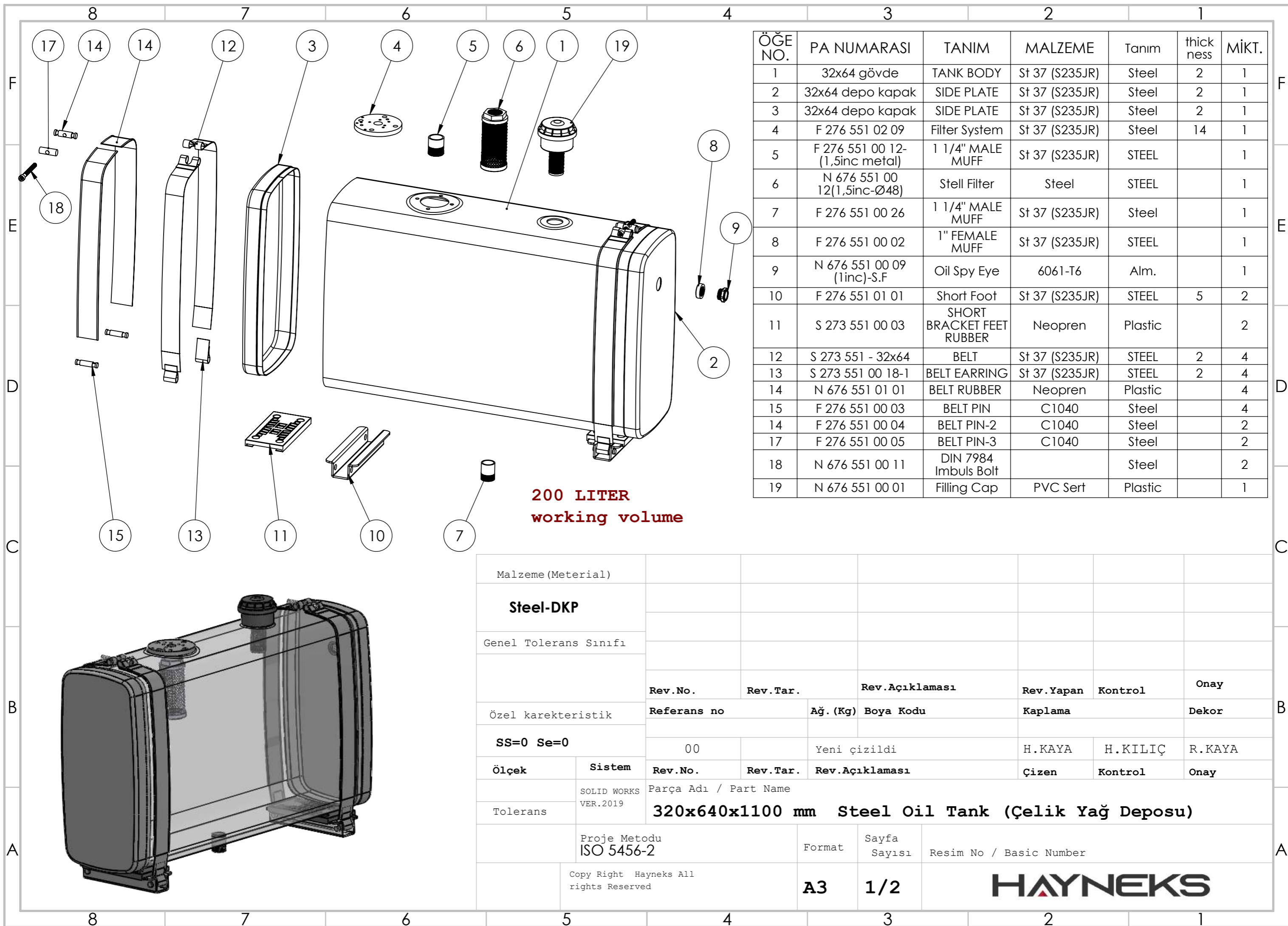

**200 LITER  
working volume**

ÖGE NO.	PA NUMARASI	TANIM	MALZEME	Tanım	thick ness	MİKT.
1	32x64 gövde	TANK BODY	St 37 (S235JR)	Steel	2	1
2	32x64 depo kapak	SIDE PLATE	St 37 (S235JR)	Steel	2	1
3	32x64 depo kapak	SIDE PLATE	St 37 (S235JR)	Steel	2	1
4	F 276 551 02 09	Filter System	St 37 (S235JR)	Steel	14	1
5	F 276 551 00 12- (1,5inc metal)	1 1/4" MALE MUFF	St 37 (S235JR)	STEEL		1
6	N 676 551 00 12(1,5inc-Ø48)	Stell Filter	Steel	STEEL		1
7	F 276 551 00 26	1 1/4" MALE MUFF	St 37 (S235JR)	Steel		1
8	F 276 551 00 02	1" FEMALE MUFF	St 37 (S235JR)	STEEL		1
9	N 676 551 00 09 (1inc)-S.F	Oil Spy Eye	6061-T6	Alm.		1
10	F 276 551 01 01	Short Foot	St 37 (S235JR)	STEEL	5	2
11	S 273 551 00 03	SHORT BRACKET FEET RUBBER	Neopren	Plastic		2
12	S 273 551 - 32x64	BELT	St 37 (S235JR)	STEEL	2	4
13	S 273 551 00 18-1	BELT EARRING	St 37 (S235JR)	STEEL	2	4
14	N 676 551 01 01	BELT RUBBER	Neopren	Plastic		4
15	F 276 551 00 03	BELT PIN	C1040	Steel		4
14	F 276 551 00 04	BELT PIN-2	C1040	Steel		2
17	F 276 551 00 05	BELT PIN-3	C1040	Steel		2
18	N 676 551 00 11	DIN 7984 Imbulş Bolt		Steel		2
19	N 676 551 00 01	Filling Cap	PVC Sert	Plastic		1

Malzeme (Material)						
<b>Steel-DKP</b>						
Genel Tolerans Sınıfı						
Rev.No.      Rev.Tar.      Rev.Açıklaması      Rev.Yapan      Kontrol      Onay						
Özel karakteristik      Referans no      Ağ. (Kg)      Boya Kodu      Kaplama      Dekor						
<b>SS=0 Se=0</b>						
00      Yeni çizildi      H.KAYA      H.KILIÇ      R.KAYA						
Ölçek      Sistem      Rev.No.      Rev.Tar.      Rev.Açıklaması      Çizen      Kontrol      Onay						
Tolerans      SOLID WORKS VER.2019      Parça Adı / Part Name						
<b>320x640x1100 mm Steel Oil Tank (Çelik Yağ Deposu)</b>						
Proje Metodu      Format      Sayfa Sayısı      Resim No / Basic Number						
ISO 5456-2      A3      1/2      HAYNEKS						
Copy Right Hayneks All rights Reserved						